



05

Ferramentas para portas e janelas
Herramientas para puertas
y machihembrados



araújo&silva
ferramentas de corte

JÁ MEDIU A SUA PRODUTIVIDADE?



A Araujo&Silva, Lda. desenvolve ferramentas especiais, proporcionando aos seus clientes as soluções mais rentáveis.

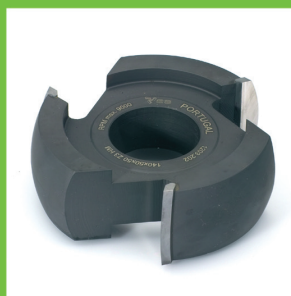

araújo&silva
ferramentas de corte

ESPECIALISTAS EM FERRAMENTA DE CORTE

www.araujosilva.pt



HW · MAN

Nr.	D	B	d	Z	n min · n max	Ref.
1	140	12	50	3	9000	7050.201
2		13	50	3	9000	7050.202
Jogo (1+2)						7050.801

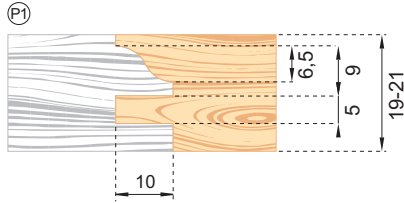

HW · MAN

Nr.	D	B	d	Z	n min · n max	Ref.
1	140	12	50	3	9000	7050.203
2		13	50	3	9000	7050.204
Jogo (1+2)						7050.802

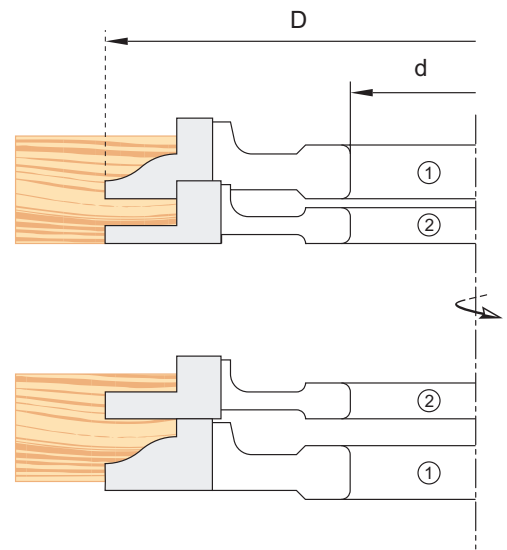
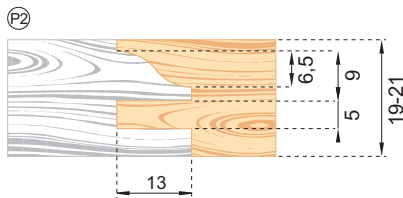

HW · MAN

Nr.	D	B	d	Z	n min · n max	Ref.
1	140	12	50	3	9000	7050.205
2		13	50	3	9000	7050.206
Jogo (1+2)						7050.803

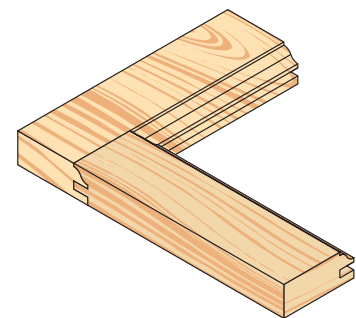
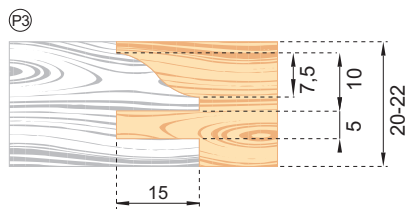

HW · MAN

Nr.	D	B	d	Z	n min · n max	Ref.
1	140	12	50	3	9000	7050.207
2		13	50	3	9000	7050.208
Jogo (1+2)						7050.804

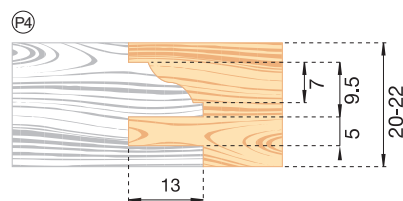



7050 Jogo de perfil e contra-perfil para portas de mobiliário Moldura e contramoldura



HW · MAN

Nr.	D	B	d	Z	n min · n max	Ref.
1	140	12	50	3	9000	7050.209
2		13	50	3	9000	7050.210
Jogo (1+2)						7050.805

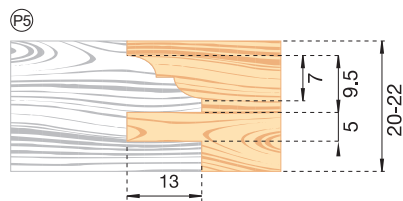

HW · MAN

Nr.	D	B	d	Z	n min · n max	Ref.
1	140	12	50	3	9000	7050.211
2		13	50	3	9000	7050.212
Jogo (1+2)						7050.806

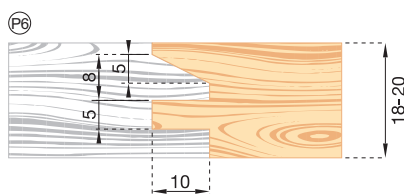

HW · MAN

Nr.	D	B	d	Z	n min · n max	Ref.
1	140	12	50	3	9000	7050.213
2		13	50	3	9000	7050.214
Jogo (1+2)						7050.807

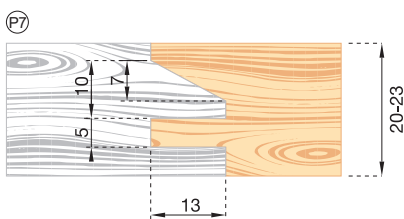

HW · MAN

Nr.	D	B	d	Z	n min · n max	Ref.
1	140	12	50	3	9000	7050.215
2		13	50	3	9000	7050.216
Jogo (1+2)						7050.808

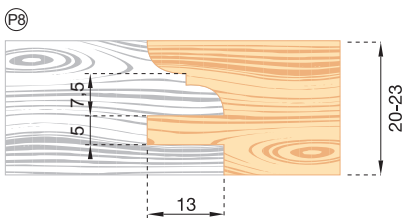

05

Ferramentas para portas e janelas · Ferramentas para portas e machihembrados

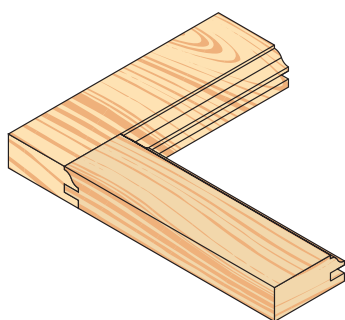
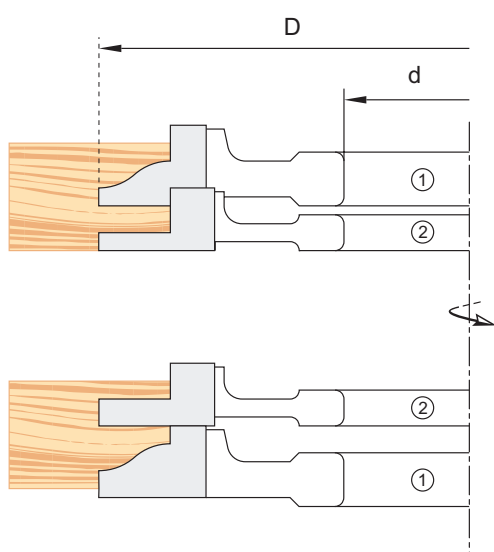



HW · MAN

Nr.	D	B	d	Z	n min · n max	Ref.
1	140	12	50	3	9000	7050.217
2		17	50	3	9000	7050.218
3		17	50	3	9000	7050.219
4		15	50	3	9000	7050.220
Jogo (1+2)						7050.809
Jogo (3+4)						7050.810

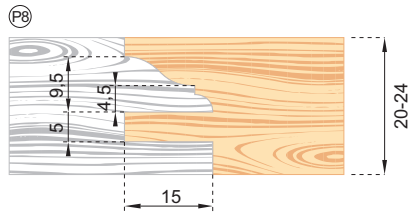

Fresa para aros de porta
Fresa para marcos de puertas

1254

HW · MEC

Nr.	D	B	d	Z	R	V	I	n max	Ref.
1	200	20	50	6		3	3	6000	1254.501
2	112	12.3	50	4	4			11000	1254.051
3	118	9	50	4		4		10000	1254.052
Jogo	1+2+3								1254.801



ACESSÓRIOS - Piezas de recambio

	Dim.	Ref.
Vincador	14x14x2	5002.01.1
Ranhurador	25x13x3	R1253
Parafuso		
Parafuso		
Chave		5302.007

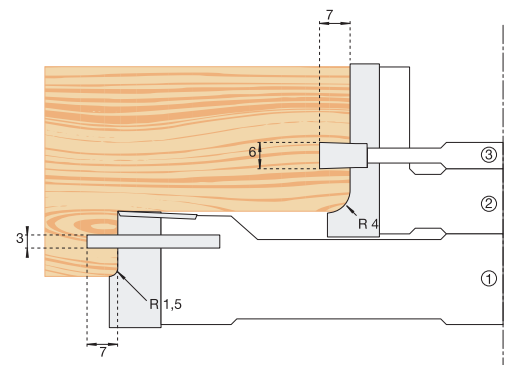



2100 Porta-lâminas para aros de portas

Cabezas para marcos de portas



HW · MEC

Nr.	D	B	d	Z	V	S	n max	Ref.
1	147	50	40	4	2	2	8800	2100.201
2	159	16	40	4			8200	2100.251
3	125	100	40	4			11400	2100.101

ACESSÓRIOS - Peças de recambio

	Nr.	Dim.	Ref.
Lâmina	1	50x12x1,5	5001.07.1
	2	16x17,5x2 (R5)	5025.04
		16x17,5x2 (45°)	5034.01
Calço	3	100x13x2,2	5001.15.1
	1		5403.048
	2		5406.014
	3		5400.098
Perno (DIN915)		M8x16	5105.007
Vincador		14x14x2	5002.01.1
Parafuso (DIN963)		M5x8	5107.003
Boleador		R1,5	5026.02
Parafuso		M5x13,5	5108.001
Chave em T		SW3 (M5)	5302.102
		SW4 (M8)	5302.103

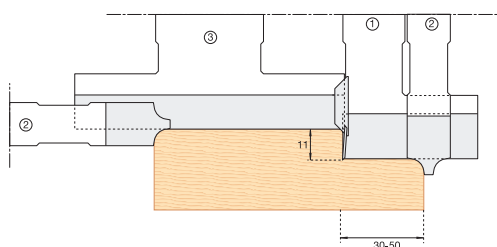
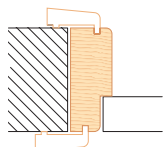

1203 Fresa de perfil convexo

Fresa perfil convexa

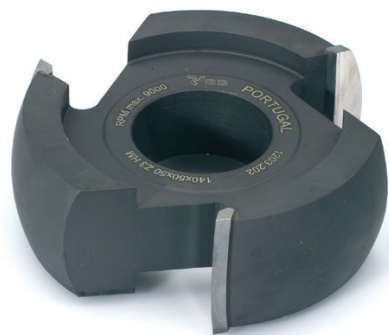

HW · MAN

Nr.	D	B	d	Z	n max	Ref.
1	140	30	50	3	9000	1203.201
2		50	50	3	9000	1203.202

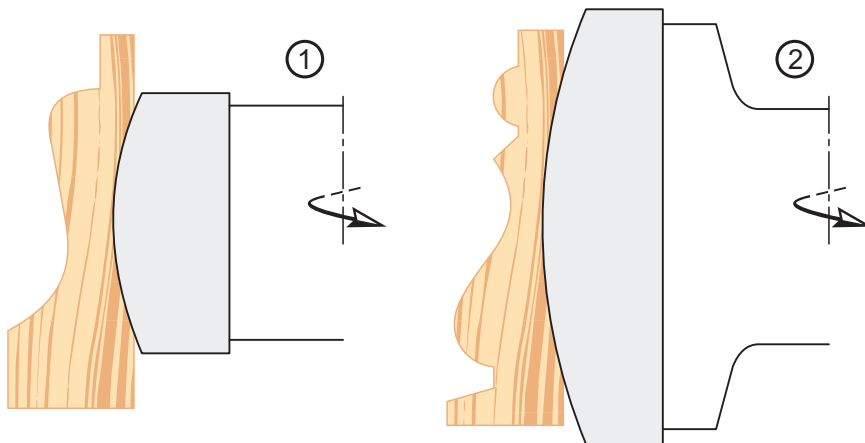

05

Ferramentas para portas e janelas · Herramientas para puertas y machihembrados

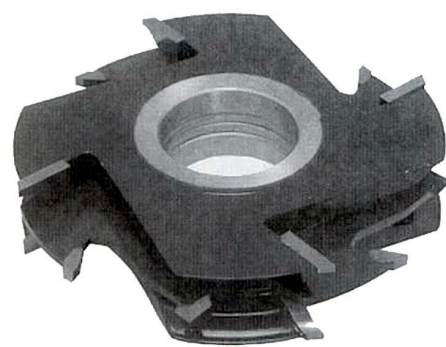
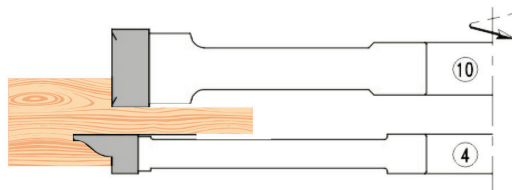
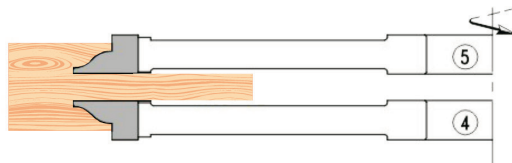
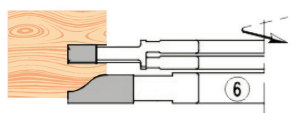
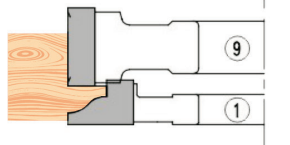
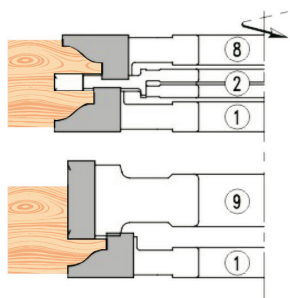
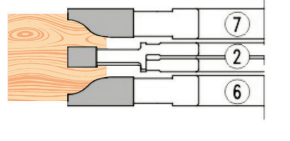
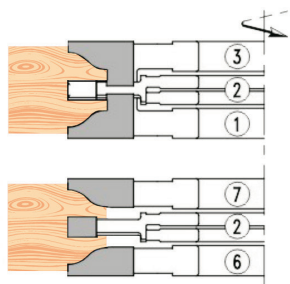

HW · MAN / MEC

PERFIS STANDARD E ESPECIAIS A PEDIDO
Perfis estándar y especiales a solicitud

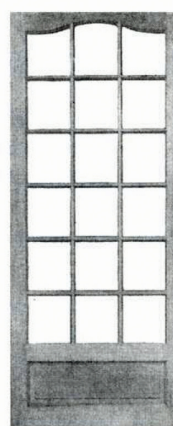

FERRAMENTAS PARA PERFIL HW
Herramientas para moldura HW / HS
D 140 – 160mm
Z 2-3-4

FERRAMENTAS PARA CONTRA-PERFIL HW
Herramientas para contramoldura HW / HS
D 280 – 320mm
Z 3

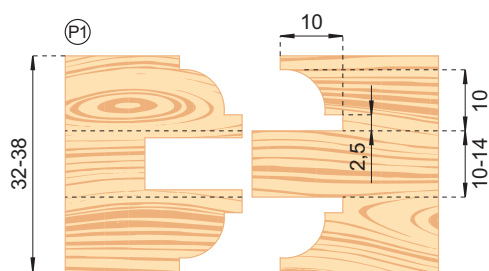

HW · MEC

Nr.	D	B	d	Z	V	n max	Ref.
6	140	13	50	4		9500	1251.201
2	150	7 – 13,5	50	4	4	8900	1251.251
7	140	19	50	4		9500	1251.202
4	320	15	50	3	3	3800	1251.801
5	320	15	50	3	3	3800	1251.802
Jogo (6+2+7)							1251.901
Jogo (4+5)							1251.902

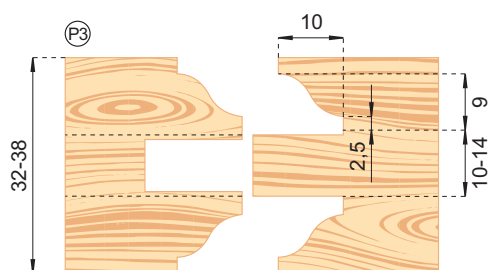

HW · MEC

Nr.	D	B	d	Z	V	n max	Ref.
1	140	17	50	4		9500	1251.203
2	150	7 – 13,5	50	4	4	8900	1251.252
3	140	17	50	4		9500	1251.204
4	320	15	50	3	3	3800	1251.803
5	320	15	50	3	3	3800	1251.804
Jogo (1+2+3)							1251.903
Jogo (4+5)							1251.904

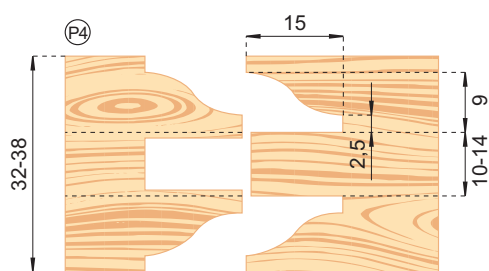

HW · MEC

Nr.	D	B	d	Z	V	n max	Ref.
1	150	17	50	4		8900	1251.253
2		7 – 13,5	50	4	4	8900	1251.254
3		17	50	4		8900	1251.255
4	320	15	50	3	3	3800	1251.805
5	320	15	50	3	3	3800	1251.806
Jogo (1+2+3)							1251.905
Jogo (4+5)							1251.906

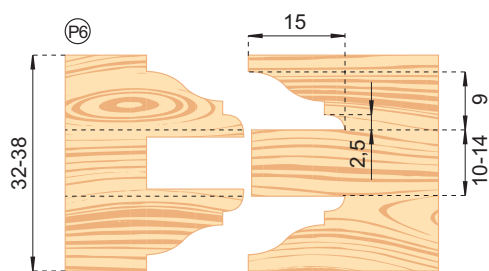

HW · MEC

Nr.	D	B	d	Z	V	n max	Ref.
1	150	17	50	4		8900	1251.256
2		7 – 13,5	50	4	4	8900	1251.257
3		17	50	4		8900	1251.258
4	320	15	50	3	3	3800	1251.807
5		15	50	3	3	3800	1251.808
Jogo (1+2+3)							1251.907
Jogo (4+5)							1251.908



HW · MEC

Nr.	D	B	d	Z	V	n max	Ref.
1	150	17	50	4		8900	1251.259
2		7 – 13,5	50	4	4	8900	1251.260
3		17	50	4		9800	1251.261
4	320	15	50	3	3	3800	1251.809
5		15	50	3	3	3800	1251.810
Jogo (1+2+3)							1251.909
Jogo (4+5)							1251.910

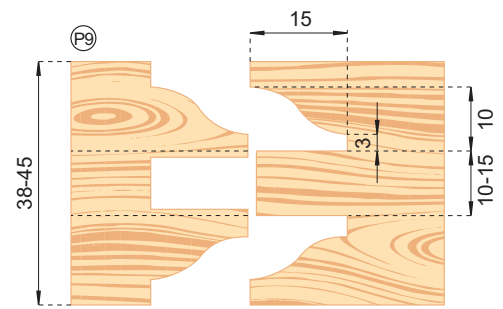

HW · MEC

Nr.	D	B	d	Z	V	n max	Ref.
1	160	20	50	4		8900	1251.301
2	150	7 – 13,5	50	4	4	8900	1251.262
3	160	20	50	4		8900	1251.302
4	320	17	50	3	3	3800	1251.811
5		17	50	3	3	3800	1251.812
Jogo (1+2+3)							1251.911
Jogo (4+5)							1251.912

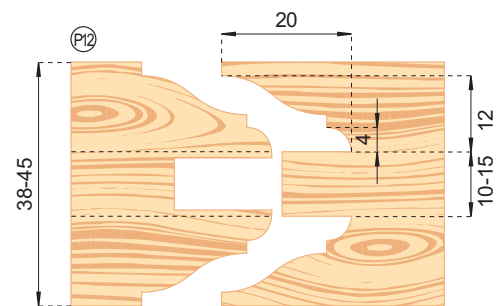

Porta-lâminas de perfil e contra perfil para portas
Moldura e contramoldura para puertas

HW · MAN

Nr.	D	B	d	Z	V	n max	Ref.
1	140	20	50	3		8000	2450.201
2		8	50	4	4	8000	2450.202
3		20	50	3		8000	2450.203
4	302	20	50	3		8000	2450.801
5		20	50	3		8000	2450.802



PORTA-LÂMINAS FORNECIDO SEM LÂMINAS

Cabezal suministrado sin cuchilla

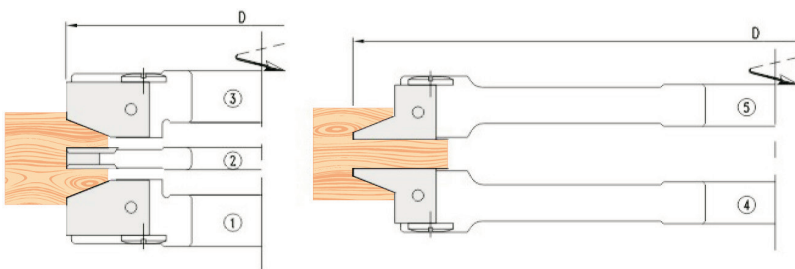



MAN - P1

Nr.	D	B	d	Z	V	n max	Ref.
1	140	12	50	4		9500	1252.201
2		20	50	4	4	9500	1252.202
3		15	50	4		9500	1252.203
4		5	50	2	2	9500	1252.204
Jogo (1+2)							1252.901
Jogo (3+4)							1252.902

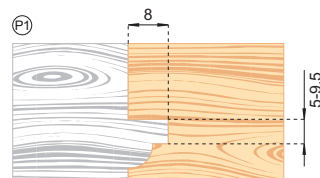

MAN - P2

Nr.	D	B	d	Z	V	n max	Ref.
1	140	12	50	4		9500	1252.205
2		20	50	4	4	9500	1252.206
3		16,5	50	4		9500	1252.207
4		5	50	2	2	9500	1252.208
Jogo (1+2)							1252.903
Jogo (3+4)							1252.904

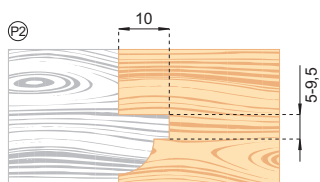

MAN - P3

Nr.	D	B	d	Z	V	n max	Ref.
1	140	12,5	50	4		9500	1252.209
2		20	50	4	4	9500	1252.210
3		15,5	50	4		9500	1252.211
4		5	50	2	2	9500	1252.212
Jogo (1+2)							1252.905
Jogo (3+4)							1252.906

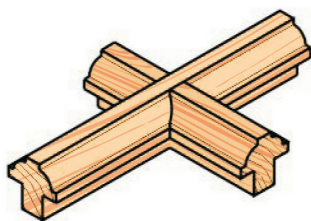
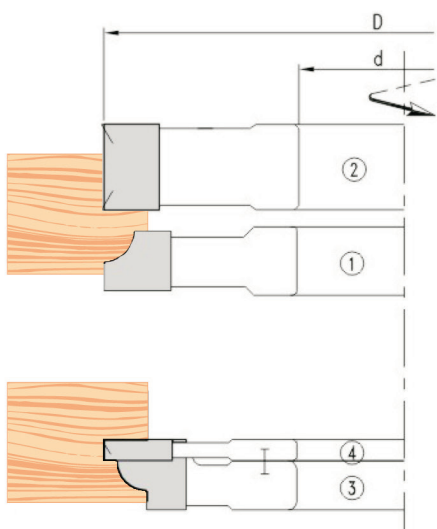
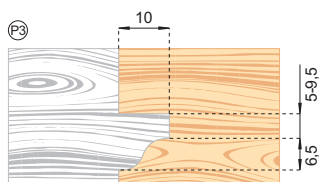



HW · MAN

Nr.	D	B	d	Z	n max	Ref.
1	140	30	50	3	9000	1201.201

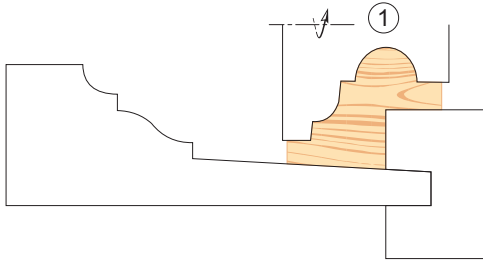

Fresa de almofadas
Fresa de plafones

1275

HW · MAN

P	D	B	d	Z	n max	Ref.
1	180	18	50	3		1275.401
	210	20	50	3		1275.551
2	180	17	50	3		1275.402
	210	20	50	3		1275.552
3	180	16	50	3		1275.403
4	180	18	50	3		1275.404
	210	20	50	3		1275.553
5	180	22	50	3		1275.405
6	200	18	50	3		1275.504
8	180	18	50	3		1275.406
10	200	16	50	3		1275.502
11	200	16	50	3		1275.503

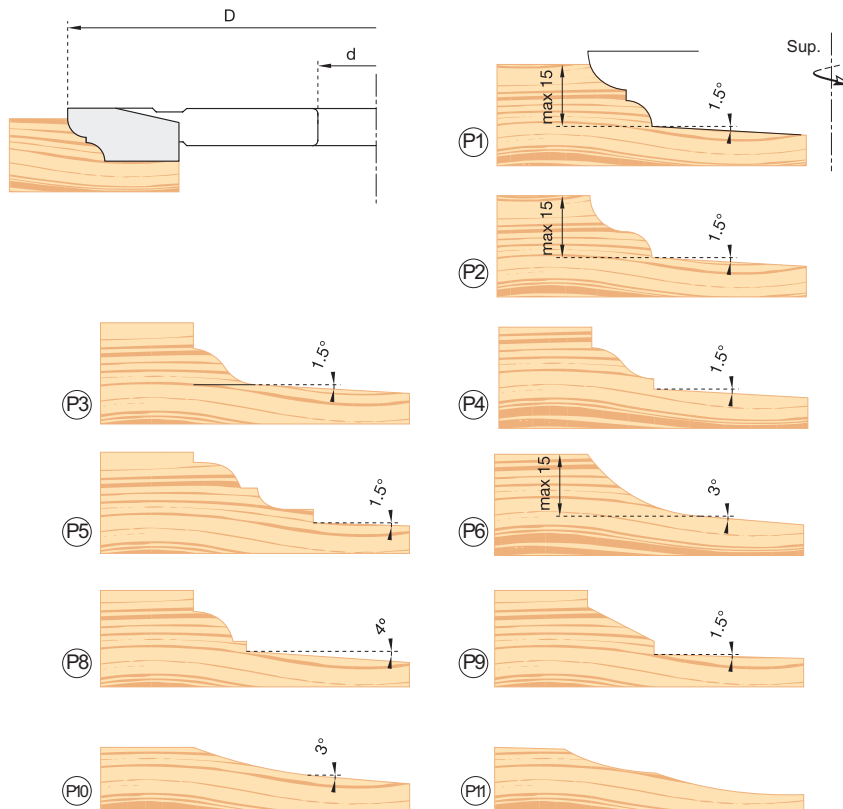



1275 Fresa de almofadas Fresa de plafones



HW · MAN

P	D	B	d	Z	n min – n max	Ref.
1	210	24	50	2+2		1275.554
2		25	50	2+2		1275.555
3		27	50	2+2		1275.556
4		28	50	2+2		1275.557
5		25	50	2+2		1275.558
6		27,5	50	2+2		1275.559
7		28	50	2+2		1275.560

05

Ferramentas para portas e janelas · Herramientas para puertas y machihembrados

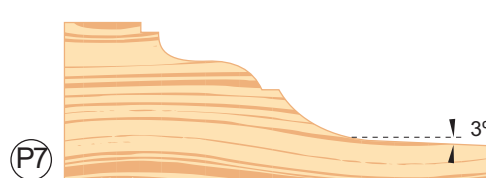
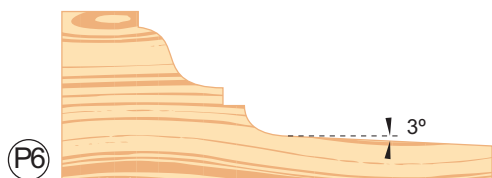
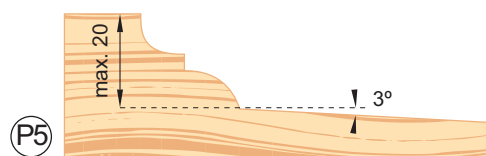
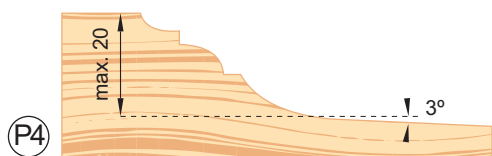
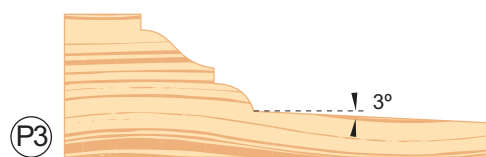
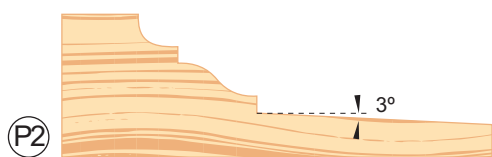
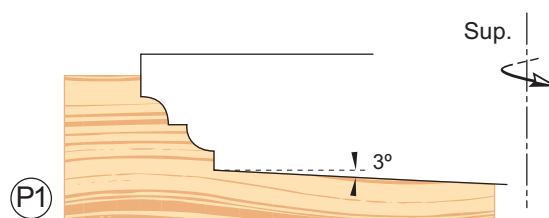
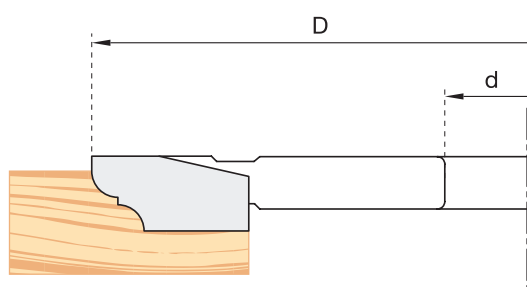



HW · MAN

D	B	d	Z	n max	Ref. Inf	Ref. Sup
180	30	30/50	2+2	7400	2475.401	2475.402

PORTA-LÂMINAS FORNECIDO COM LÂMINAS P1
Cabezal suministrado con cuchillas P1

ACESSÓRIOS - Piezas de recambio

	Nr.	Dim.	Ref.
Lâmina	1 (SUP)	20x12x1,5	2475.001
	2	20x12x1,5	2475.002
	3	20x12x1,5	2475.003
	1 (INF)	20x12x1,5	2475.101
	2	20x12x1,5	2475.102
	3	20x12x1,5	2475.103
Calço	SUP		2475.201
	INF		2475.301
Lâmina		50x12x1,5	5001.07.1
Calço			5432.020
Perno (DIN915)		M8x16	5105.007

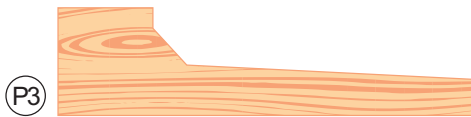
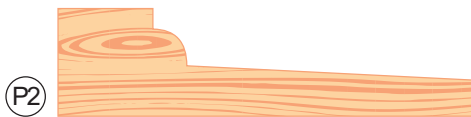
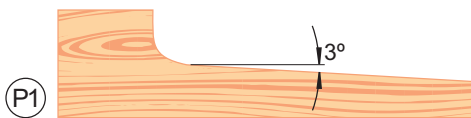
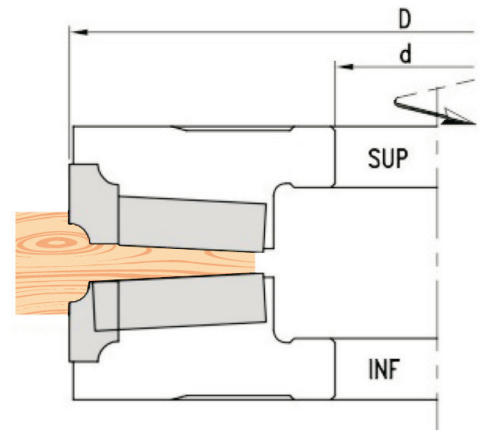



2475 Porta-lâminas para almofadas Cabezal de plafones



HW · MAN

D	B	d	Z	n max	Ref. Inf	Ref. Sup
200	30	30/50	2+2	6600	2475.403	2475.404

PORTA-LÂMINAS FORNECIDO COM LÂMINAS P1. A PEDIDO P2, P3.
Cabezal suministrado con cuchillas P1. A solicitud P2, P3.

ACESSÓRIOS - Piezas de recambio

	Nr.	Dim.	Ref.
Lâmina	1 (SUP)	20x12x1,5	2475.001
	2	20x12x1,5	2475.002
	3	20x12x1,5	2475.003
	1 (INF)	20x12x1,5	2475.101
	2	20x12x1,5	2475.102
	3	20x12x1,5	2475.103
Calço	SUP		2475.201
	INF		2475.301
Lâmina	SUP	60x12x1,5	2475.004
	INF	60x12x1,5	2475.104
Calço	SUP		2475.202
	INF		2475.302
Perno (DIN915)		M8x16	5105.007

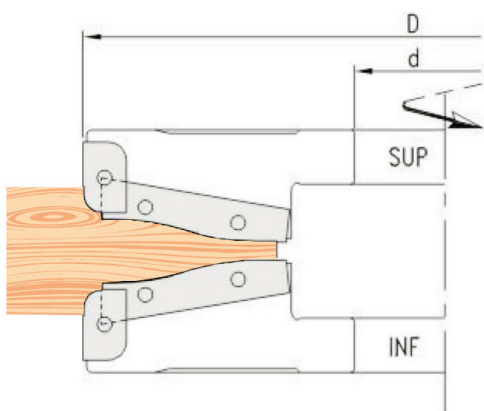

(P1)

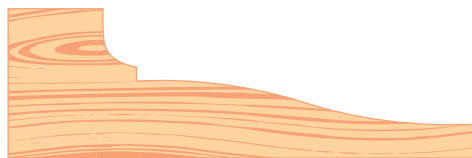

(P2)

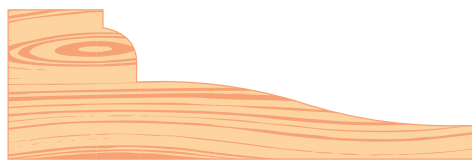

(P3)

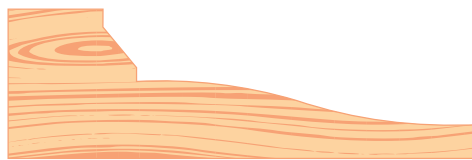

05

Ferramentas para portas e janelas · Herramientas para puertas y machihembrados



HW · MAN

D	B	d	Z	n max	Ref. Inf	Ref. Sup
205	30	30/50	2+2	6300	2475.405	2475.406

PORTA-LÂMINAS FORNECIDO COM LÂMINAS P1. A PEDIDO P2, P3, P4.
Cabezal suministrado con cuchillas P1. A solicitud P2, P3, P4.

ACESSÓRIOS - Piezas de recambio

	Nr.	Dim.	Ref.
Lâmina	1 (SUP)	25x30x2	2475.501
	2	25x30x2	2475.502
	3	25x30x2	2475.503
	4	25x30x2	2475.504
Lâmina	1 (INF)	25x30x2	2475.601
	2	25x30x2	2475.602
	3	25x30x2	2475.603
	4	25x30x2	2475.604
Calço	SUP		2475.701
	INF		2475.702
Lâmina		50x12x1,5	5001.07.1
Calço	SUP		5432.020
Perno (DIN915)		M8x16	5105.007
		M10x16	5105.010

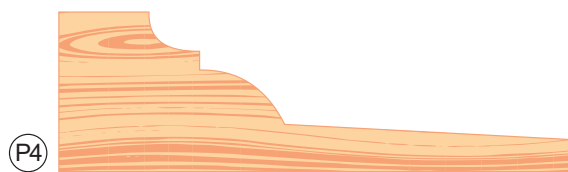
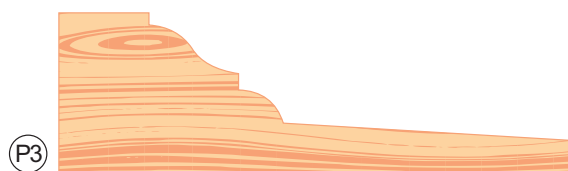
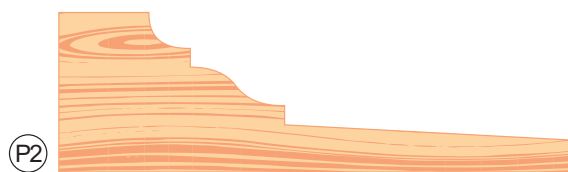
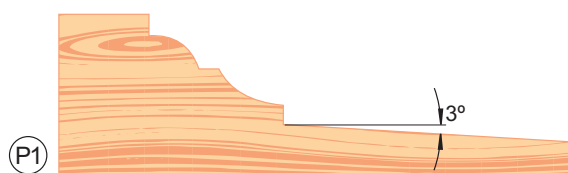
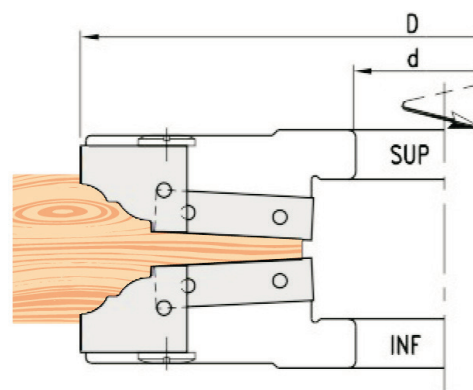

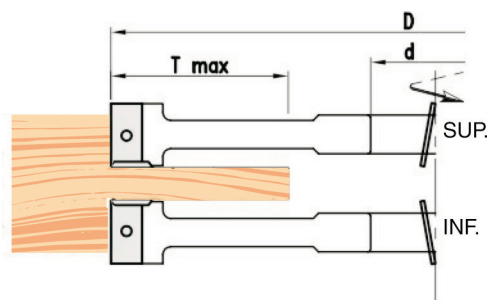

HW · MAN

D	B	d	Z	V	T max	n max	Ref. Inf	Ref. Sup
250	20	50	3	3	90	5300	2025.751	2025.752
	25	50	3	3	90	5300	2025.753	2025.754
	30	50	3	3	90	5300	2025.755	2025.756
	40	50	3	3	90	5300	2025.757	2025.758
272	30	50	3	3	100	4900	2025.759	2025.760
	40	50	3	3	100	4900	2025.761	2025.762
280	20	50	3	3	105	4700	2025.763	2025.764
	25	50	3	3	105	4700	2025.765	2025.766
	30	50	3	3	105	4700	2025.767	2025.768
	40	50	3	3	105	4700	2025.769	2025.770
300	20	50	3	3	115	4400	2025.771	2025.772
	25	50	3	3	115	4400	2025.773	2025.774
	30	50	3	3	115	4400	2025.775	2025.776
	40	50	3	3	115	4400	2025.777	2025.778
302	30	50	3	3	115	4400	2025.779	2025.780
	40	50	3	3	115	4400	2025.781	2025.782
320	20	50	3	3	125	4100	2025.783	2025.784
	25	50	3	3	125	4100	2025.785	2025.786
	30	50	3	3	125	4100	2025.787	2025.788
	40	50	3	3	125	4100	2025.789	2025.790

ACESSÓRIOS - Peças de recambio

	Dim.	Ref.
Lâmina	20x12x1,5	5000.12.1
	25x12x1,5	5000.16.1
	30x12x1,5	5001.01.1
	40x12x1,5	5001.05.1
Calço		5400.018
		5400.023
		5400.028
		5400.038
Perno (DIN915)	M8x16	5105.007
Vincador	14x14x2	5002.01.1
Parafuso (DIN963)	M5x8	5107.003
Chave em T	SW4 (M8)	5302.103



HW · MAN

D	B	d	Z	V	T max	n max	Ref.
250	8	30/50	3	6	90	5300	2026.752
	10	30/50	3	6	90	5300	2026.754
	12	30/50	3	6	90	5300	2026.756
	15	30/50	3	6	90	5300	2026.758
	20	30/50	3	6	90	5300	2026.760
272	8	30/50	3	6	100	4900	2026.762
	10	30/50	3	6	100	4900	2026.764
	12	30/50	3	6	100	4900	2026.766
	15	30/50	3	6	100	4900	2026.768
	20	30/50	3	6	100	4900	2026.770
280	8	30/50	3	6	105	4700	2026.772
	10	30/50	3	6	105	4700	2026.774
	12	30/50	3	6	105	4700	2026.776
	15	30/50	3	6	105	4700	2026.778
	20	30/50	3	6	105	4700	2026.780
302	8	30/50	3	6	115	4400	2026.782
	10	30/50	3	6	115	4400	2026.784
	12	30/50	3	6	115	4400	2026.786
	15	30/50	3	6	115	4400	2026.788
	20	30/50	3	6	115	4400	2026.790

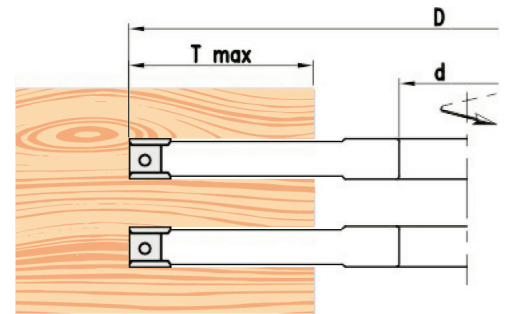

ACESSÓRIOS - Peças de recambio

	Dim.	Ref.	
Lâmina	7,6x12x1,5	5000.01.1	
	9,6x12x1,5	5000.04.1	
	11,6x12x1,5	5000.06.1	
	14,6x12x1,5	5000.08.1	
	19,6x12x1,5	5000.13.1	
Calço		5400.006	
		5400.008	
		5400.010	
		5400.018	
Perno (DIN915)	8	M5x12	5105.001
	10	M6x12	5105.005
	12/20	M8x16	5105.007
Vincador	14x14x2	5002.01.1	
Parafuso (DIN963)	8/10	M5x6	5107.002
	12/20	M5x8	5107.003
Chave em T	SW2 (M5)	5302.101	
	SW3 (M6)	5302.102	
	SW4 (M8)	5302.103	



1026 Fresa para respigar Fresa para espigar



PRODUÇÃO A PEDIDO

Sobre pedido

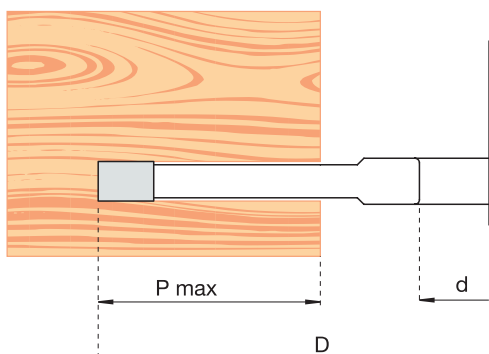

HW · MAN

D	B	d	Z	V	T max	n max	Ref.
250	18	50	3	3	90	5300	INF 1026.751
	24	50	3	3	90	5300	INF 1026.753
	30	50	3	3	90	5300	INF 1026.755
	40	50	3	3	90	5300	INF 1026.757
	18	50	3	3	90	5300	SUP 1026.752
	24	50	3	3	90	5300	SUP 1026.754
	30	50	3	3	90	5300	SUP 1026.756
	40	50	3	3	90	5300	SUP 1026.758
300	18	50	3	3	115	4400	INF 1026.801
	24	50	3	3	115	4400	INF 1026.803
	30	50	3	3	115	4400	INF 1026.805
	40	50	3	3	115	4400	INF 1026.807
	18	50	3	3	115	4400	SUP 1026.802
	24	50	3	3	115	4400	SUP 1026.804
	30	50	3	3	115	4400	SUP 1026.806
	40	50	3	3	115	4400	SUP 1026.808
320	18	50	3	3	125	4100	INF 1026.809
	24	50	3	3	125	4100	INF 1026.811
	30	50	3	3	125	4100	INF 1026.813
	40	50	3	3	125	4100	INF 1026.815
	18	50	3	3	125	4100	SUP 1026.810
	24	50	3	3	125	4100	SUP 1026.812
	30	50	3	3	125	4100	SUP 1026.814
	40	50	3	3	125	4100	SUP 1026.816

1027 Fresa para respigar Fresa para espigar



PRODUÇÃO A PEDIDO

Sobre pedido

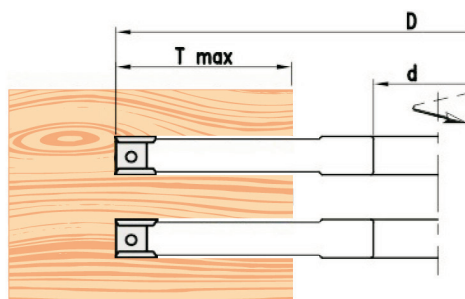

HW · MAN

D	B	d	Z	T max	n max	Ref.
250	8	50	3	90	5300	1027.751
	10	50	3	90	5300	1027.752
	12	50	3	90	5300	1027.753
	15	50	3	90	5300	1027.754
272	8	50	3	100	4900	1027.801
	10	50	3	100	4900	1027.802
	12	50	3	100	4900	1027.803
	15	50	3	100	4900	1027.804
280	8	50	3	105	4700	1027.805
	10	50	3	105	4700	1027.806
	12	50	3	105	4700	1027.807
	15	50	3	105	4700	1027.808
302	8	50	3	115	4400	1027.809
	10	50	3	115	4400	1027.810
	12	50	3	115	4400	1027.811
	15	50	3	115	4400	1027.812



araújo&silva
ferramentas de corte

www.araujosilva.pt